

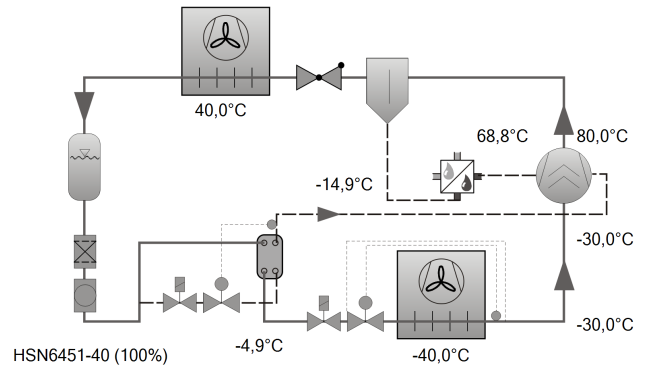

Selection: Semi-hermetic Screw Compressors HS

Input Values

Compressor model	HSN6451-40
Refrigerant	R404A
Reference temperature	Dew point temp.
Evaporating SST	-40,00 °C
Condensing SDT	40,0 °C
Liq. subc. (in condenser)	0 K
Auto. subcooling	Auto
Suct. gas superheat	10,00 K
Operating mode	Economiser
Power supply	400V-3-50Hz
Useful superheat	100%
Additional cooling	Automatic
Max. discharge gas temp.	80,0 °C



Result

Compressor	HSN6451-40-40P
Capacity steps	100%
Cooling capacity	32,2 kW
Cooling capacity *	33,2 kW
Evaporator capacity	32,2 kW
Power input	31,8 kW
Current (400V)	53,2 A
Voltage range	380-415V
Condenser capacity	56,3 kW
COP/EER	1,01
COP/EER *	1,03
Mass flow LP	733 kg/h
Mass flow HP	1186 kg/h
Operating mode	Economiser
Liquid temp. (sc)	-4,94 °C
Mass flow ECO	453 kg/h
sub cooler load	13,48 kW
sat. ECO Temp.	-14,94 °C
ECO pressure	3,65 bar(a)
Oil volume flow	1,35 m³/h
Cooling method	External
Oil cooler outlet	68,8 °C
Oil cooler load	7,82 kW
Discharge gas temp. w/o cooling	100,9 °C

Additional cooling/ limitations (see Limits)!

*According to EN12900 (10K suction gas superheat, liquid subcooling in Economiser with 5K temperature difference)

Application Limits ECO HSN6451-40

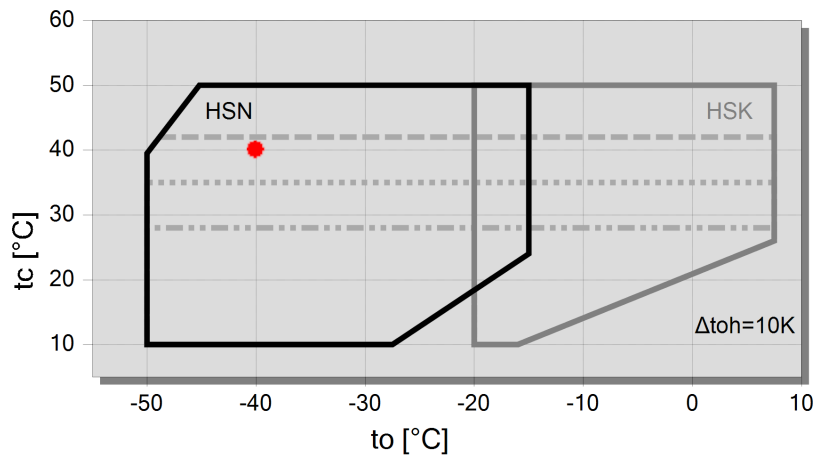

Legend

- max. t_c for frequencies = 20Hz
- max. t_c for frequencies = 25Hz
- max. t_c for frequencies = 35Hz
- A



Technical Data: HSN6451-40

Dimensions and Connections

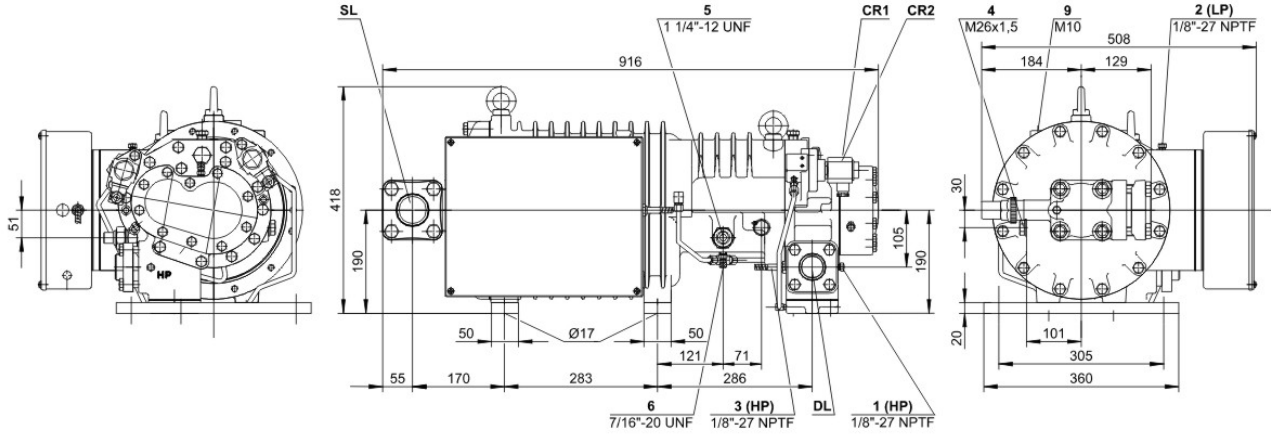



Technical Data

Technical Data

Displacement (2900rpm 50 Hz)	140 m ³ /h
Displacement (3500rpm 60 Hz)	168 m ³ /h
Weight	234 kg
Max. pressure (LP/HP)	19 / 28 bar
Connection suction line	54 mm - 2 1/8"
Connection discharge line	42 mm - 1 5/8"
Adapter/shut-off valve for ECO	22 mm - 7/8" (Option)
Oil type R22	B150SH, B100 (Option)
Oil type R134a/R404A/R507A/R407A/R407F	BSE170
Oil type R448A/R449A/R454C	BSE170

Motor data

Motor version	1
Motor voltage (more on request)	380-415V PW-3-50Hz
Max. operating current	65.0 A
Starting current (Rotor locked)	187.0 A D / 313.0 A DD
Max. power input	42,1 kW

Extent of delivery (standard)

Discharge gas temperature sensor	Standard
Start unloading	Standard
Oil flow control	SE-B3 (Standard)
Motor protection	SE-E1 (Standard), SE-E3 (Standard for 660-690V)
Suction shut-off valve	Standard
Capacity control	100-75-50% (Standard)
Enclosure class	IP54

Available options

Discharge shut-off valve	Option
ECO connection with shut-off valve	Option
Motor protection	SE-i1 (200-690V)

Sound measurement

Sound power level (-35°C / 40°C)	86,5 dB(A)
Sound pressure level @ 1m (-35°C / 40°C)	78,5 dB(A)



Semi-hermetic Screw Compressors HS

HSK = Application for air-conditioning and medium temperature cooling.

HSN = Application for low temperature cooling.

Notes regarding application limits (see "Limits")

- * Ranges are valid for standard operation and at full-load conditions.
- * With high pressure conditions, part-load operation is partly limited (see application limits in applications manual SH-100).
- * With Economizer operation the maximum admissible evaporation temperature is shifted by 10K downward (otherwise there is a danger of excessive compression and overload of the motor because of a higher mass flow). At pull-down conditions from higher evaporation temperatures, the ECO injection must remain closed until the evaporation temperature is below the maximum admissible value and a stable operation is achieved (e.g. control of the ECO solenoid valve by means of a low pressure cut-out). The use of the ECO-system with higher evaporation temperatures requires individual consultation with Bitzer.

HS 64/74

- * Capacity control with ECO operation at the same time is limited to one single regulating step (CR 75%). At CR 50% the ECO injection should be closed.

Data for sound emission

Data are based on 50Hz application (IP-units 60Hz) and R404A.

Sound pressure level: values are based on open air test sites with semi-spherical sound emissions at 1 meter distance. For further information see Technical Information "Sound Data".



Selection: Semi-hermetic Screw Compressors HS

Input Values

Compressor model	HSN7471-75
Refrigerant	R404A
Reference temperature	Dew point temp.
Evaporating SST	-40,00 °C
Condensing SDT	40,0 °C
Liq. subc. (in condenser)	0 K
Auto. subcooling	Auto
Suct. gas superheat	10,00 K
Operating mode	Economiser
Power supply	400V-3-50Hz
Useful superheat	100%
Additional cooling	Automatic
Max. discharge gas temp.	80,0 °C

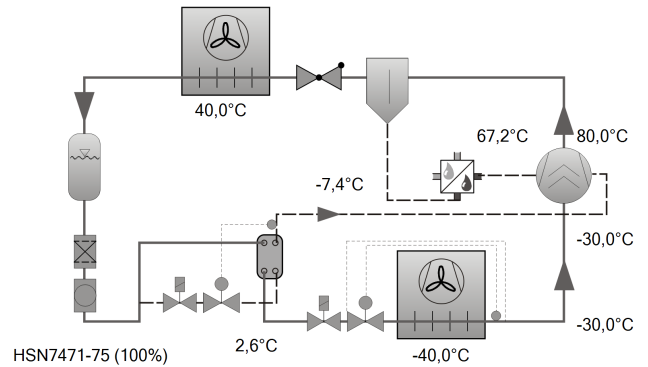

Result

Compressor	HSN7471-75-40P
Capacity steps	100%
Cooling capacity	54,5 kW
Cooling capacity *	56,2 kW
Evaporator capacity	54,5 kW
Power input	53,1 kW
Current (400V)	85,2 A
Voltage range	380-415V
Condenser capacity	94,7 kW
COP/EER	1,03
COP/EER *	1,05
Mass flow LP	1330 kg/h
Mass flow HP	1996 kg/h
Operating mode	Economiser
Liquid temp. (sc)	2,56 °C
Mass flow ECO	666 kg/h
sub cooler load	20,6 kW
sat. ECO Temp.	-7,44 °C
ECO pressure	4,74 bar(a)
Oil volume flow	1,97 m³/h
Cooling method	External
Oil cooler outlet	67,2 °C
Oil cooler load	12,96 kW
Discharge gas temp. w/o cooling	100,6 °C

Additional cooling/ limitations (see Limits)!

*According to EN12900 (10K suction gas superheat, liquid subcooling in Economiser with 5K temperature difference)

Application Limits ECO HSN7471-75

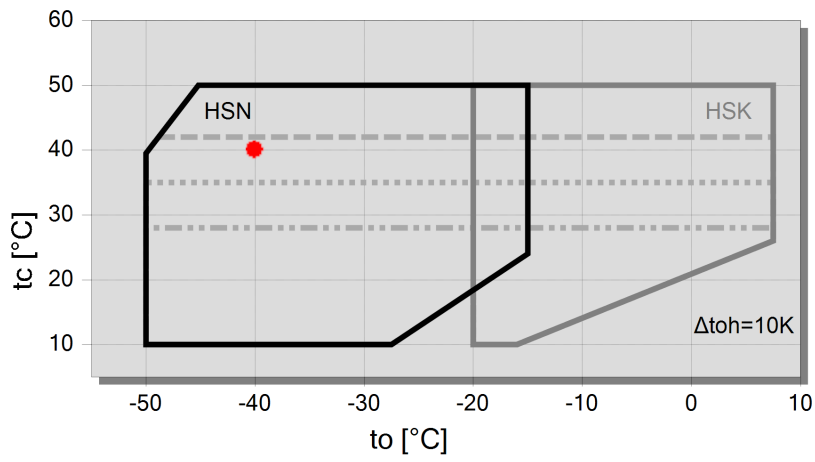

Legend

- max. tc for frequencies = 20Hz
- max. tc for frequencies = 25Hz
- max. tc for frequencies = 35Hz
- A



Technical Data: HSN7471-75

Dimensions and Connections

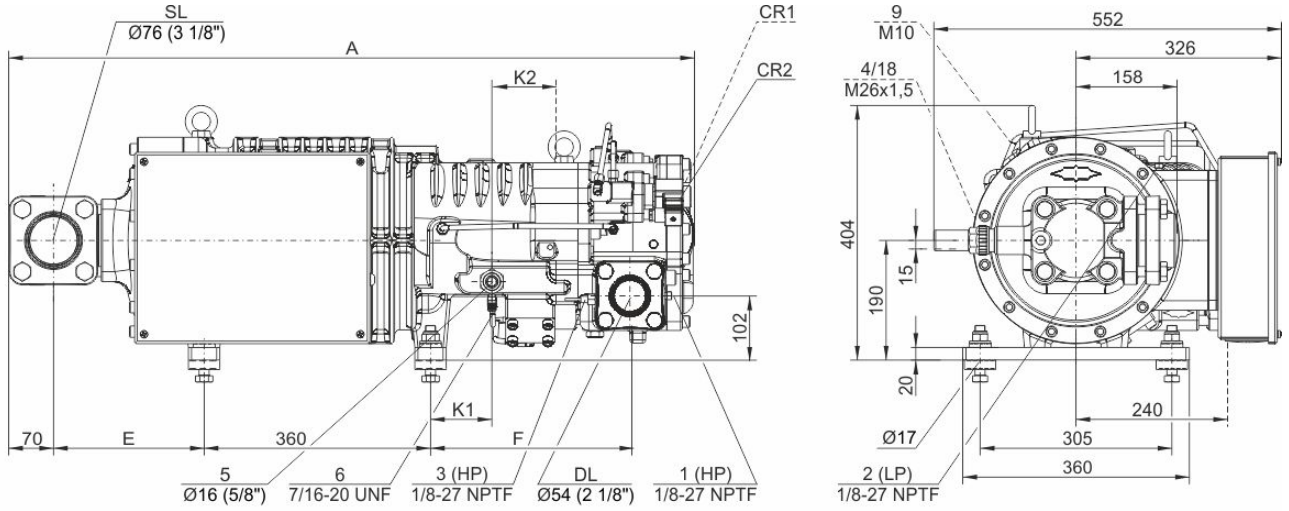

Model	A	E	F	K1	K2
	mm	mm	mm	mm	mm
HS.7451, HS.7461	1021	186	295	76	109
HSK7471-70, HSN7471-75	1034	186	318	98	97
HSK7471-90	1087	238	318	98	97



Technical Data

Technical Data

Displacement (2900rpm 50 Hz)	250 m ³ /h
Displacement (3500rpm 60 Hz)	302 m ³ /h
Weight	326 kg
Max. pressure (LP/HP)	19 / 28 bar
Connection suction line	76 mm - 3 1/8"
Connection discharge line	54 mm - 2 1/8"
Adapter/shut-off valve for ECO	22 mm - 7/8" (Option)
Oil type R22	B150SH, B100 (Option)
Oil type R134a/R404A/R507A/R407A/R407F	BSE170
Oil type R448A/R449A/R454C	BSE170

Motor data

Motor version	1
Motor voltage (more on request)	380-415V PW-3-50Hz
Max. operating current	144.0 A
Starting current (Rotor locked)	350.0 A D / 585.0 A DD
Max. power input	85,0 kW

Extent of delivery (standard)

Discharge gas temperature sensor	Standard
Start unloading	Standard
Oil flow control	SE-B3 (Standard)
Motor protection	SE-E1 (Standard), SE-E3 (Standard for 660-690V)
Suction shut-off valve	Standard
Capacity control	100-75-50% (Standard)
Enclosure class	IP54

Available options

Discharge shut-off valve	Option
ECO connection with shut-off valve	Option
Motor protection	SE-i1 (200-690V)

Sound measurement

Sound power level (-35°C / 40°C)	87,5 dB(A)
Sound pressure level @ 1m (-35°C / 40°C)	79,5 dB(A)



Semi-hermetic Screw Compressors HS

HSK = Application for air-conditioning and medium temperature cooling.

HSN = Application for low temperature cooling.

Notes regarding application limits (see "Limits")

- * Ranges are valid for standard operation and at full-load conditions.
- * With high pressure conditions, part-load operation is partly limited (see application limits in applications manual SH-100).
- * With Economizer operation the maximum admissible evaporation temperature is shifted by 10K downward (otherwise there is a danger of excessive compression and overload of the motor because of a higher mass flow). At pull-down conditions from higher evaporation temperatures, the ECO injection must remain closed until the evaporation temperature is below the maximum admissible value and a stable operation is achieved (e.g. control of the ECO solenoid valve by means of a low pressure cut-out). The use of the ECO-system with higher evaporation temperatures requires individual consultation with Bitzer.

HS 64/74

- * Capacity control with ECO operation at the same time is limited to one single regulating step (CR 75%). At CR 50% the ECO injection should be closed.

Data for sound emission

Data are based on 50Hz application (IP-units 60Hz) and R404A.

Sound pressure level: values are based on open air test sites with semi-spherical sound emissions at 1 meter distance. For further information see Technical Information "Sound Data".